

▲ GROUND SUPPORT PLATE

▲ PART NO: 912320

- ▲ USED WITH SOCKET BASE
- ▲ THREE MOUNTING POINTS M16
- ▲ WEIGHT 17 LB 7 OZ
- ▲ ZINK PLATED AND POWDER COATED
- ▲ DELIVERED IN STACKABLE STILLAGE 100 PCS.

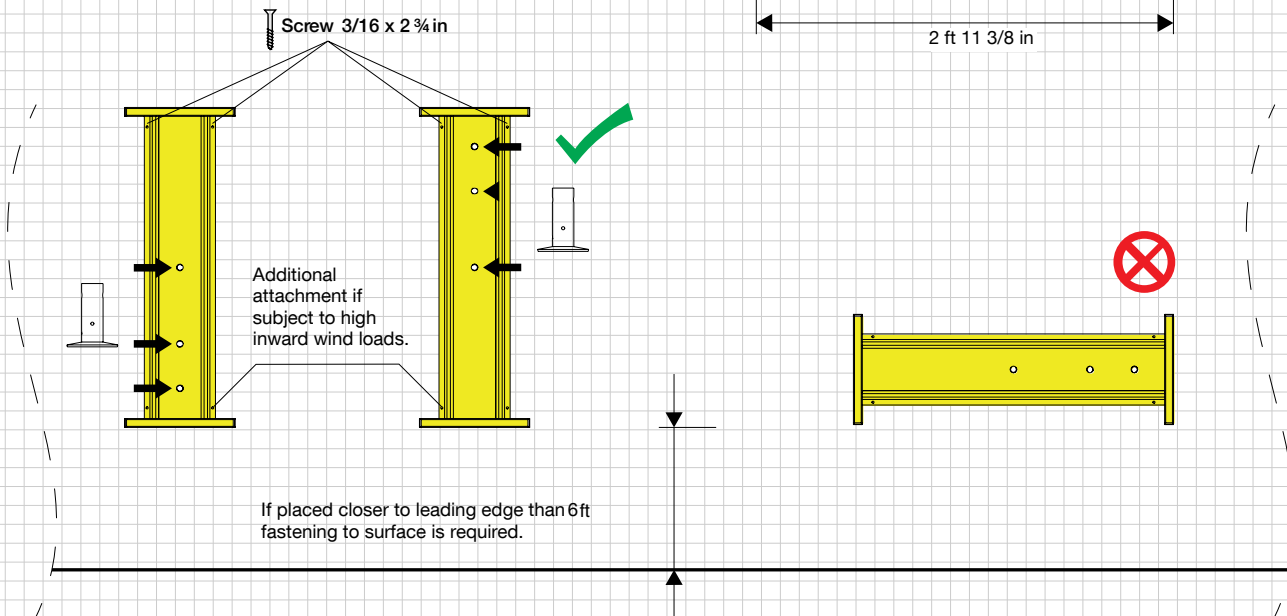
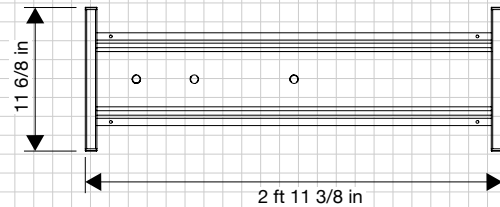
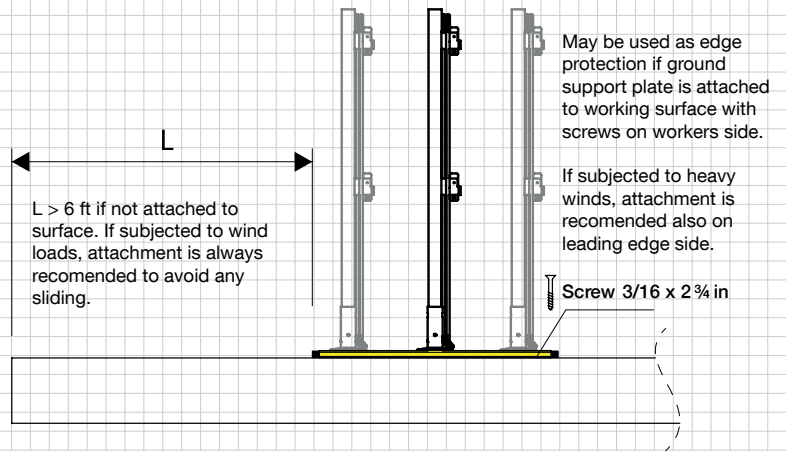

We reserve the right to make technical changes.

